

PureView® Series USB Pulsar Receiver Operator Manual

PureView User Manual

Version 1.3

January 2021



JSR  **Ultrasonics**

Copyright 2021. All Rights Reserved

This information in this document is applicable to all models in the PureView™ Pulser-Receiver Instrument series.

Copyright© 2021 by Imaginant Inc. This manual is protected by United States copyright law and international treaty provisions. All rights reserved. Imaginant and PureView™ are registered trademarks of Imaginant Inc.

PureView™ is abbreviated as PureView throughout this manual.

Microsoft and Windows are registered trademarks or trademarks of Microsoft Corporation in the United States and/or other countries.

Safety Advisories

**English**

The PureView system is designed for manufacturing, laboratory, and office use.

Français /French

Le système PureView est conçu pour la fabrication, les laboratoires et les bureaux.

Español /Spanish

El sistema PureView está diseñado para uso en fabricación, laboratorio y oficina.

Deutsch /German

Das PureView-System ist für den Einsatz in der Fertigung, im Labor und im Büro konzipiert.

汉语 /Chinese

PureView 系统专为制造，实验室和办公室使用而设计。

日本語 /Japanese

PureView システムは、製造、実験室、およびオフィスでの使用のために設計されています。

Italiano /Italian

Il sistema PureView è progettato per la produzione, il laboratorio e l'uso in ufficio.

Português /Portuguese

O sistema PureView foi projetado para uso em fabricação, laboratório e escritório.

Русско /Russian

Система PureView предназначена для производства, лабораторного и офисного использования.

한국어 /Korean

PureView 시스템은 제조, 실험실 및 사무용으로 설계되었습니다.



English

Use the PureView instrumentation as directed by the manufacturer. If you do not use as directed, overall safety could potentially be compromised.

Français /French

Si les instruments PureView ne sont pas employés selon les prescriptions du fabricant, la sécurité globale peut en être affectée.

Español /Spanish

Utilice la instrumentación del PureView según lo dirigido por el fabricante. Si usted no utiliza según lo dirigido, la seguridad total podría potencialmente ser comprometida.

Deutsch /German

Verwenden Sie die PureView Instrumentenausrüstung, wie durch den Hersteller verwiesen. Wenn Sie verwenden nicht, wie verwiesen, könnte Gesamtsicherheit möglicherweise gekompromittiert werden.

汉语 /Chinese

使用 PureView 仪器工作如指挥的是由制造商。如果您不使用如被指挥，整体安全可能潜在地减弱。

日本語 /Japanese

製造業者によって指示されるように PureView の器械使用を使用しなさい。指示されるように使用しなかったら、全面的な安全は可能性としては妥協されてもよい。

Italiano /Italian

Usi la strumentazione del PureView come diretta dal fornitore. Se non usate come diretto, la sicurezza generale potrebbe potenzialmente essere compromessa.

Português /Portuguese

Use a instrumentação do PureView como dirigida pelo fabricante. Se você não se usa como dirigido, a segurança total poderia potencial ser comprometida.

Русско /Russian

Используйте измерительное оборудование PureView как сразу изготовлением. Если вы не используете как сразу, то общая безопасность смогла потенциально быть скомпрометирована.

한국어 /Korean

제조사에 의해 지시되는 것과 같이 PureView 기계 사용을 사용하십시오. 당신이 지시되는 것과 같이 사용하지 않는 경우에, 전반적인 안전은 잠재적으로 손상될 수 있었다.

Table of Contents

SAFETY ADVISORIES	2
HARDWARE LIMITED WARRANTY	7
SOFTWARE LIMITED WARRANTY AND LICENSE AGREEMENT	7
APPLICATION DISCLAIMER	7
POWERING PUREVIEW INSTRUMENTS	7
PRODUCT PACKAGE CONTENTS	8
ADDITIONAL EQUIPMENT REQUIRED (CUSTOMER SUPPLIED)	8
OVERVIEW	9
THEORY OF OPERATION	9
PUREVIEW INSTRUMENT FUNCTIONAL BLOCKS	9
Control Logic and USB Interface.....	10
Pulser (Energy and Damping).....	10
Pulser Voltage	10
T/R and Through Select	11
Amplifier/Attenuator.....	11
Low Pass Filters	11
High Pass Filters.....	11
PUREVIEW ENCLOSURE, INTERFACE CONNECTORS, AND STATUS INDICATORS	12
PUREVIEW T/R AND THROUGH CONNECTORS	12
PUREVIEW RECEIVER OUTPUT, TRIG/SYNC, AND USB CONNECTORS	13
PUREVIEW STATUS INDICATORS.....	14
PC SETUP	14
SYSTEM CONFIGURATION	15
PULSE-ECHO CONFIGURATION	15
THROUGH MODE CONFIGURATION	16
PUREVIEW OPERATION	16

USING JSR .NET CONTROL PANEL SOFTWARE 18

RECEIVER CONTROLS IN JSR .NET CONTROL PANEL..... 19

 Power LED 19

 Receiver Mode 19

 Gain..... 19

 Low Pass Filter..... 19

 High Pass Filter 19

PULSER CONTROLS IN JSR .NET CONTROL PANEL 19

 Trigger Enable 19

 Trigger Source 19

 PRF..... 19

 Pulsar Voltage Supply Enable..... 20

 Pulsar Voltage 20

 Pulsar Energy..... 20

 Damping..... 20

 Trigger Zin 20

INSTRUMENT STATUS INDICATORS IN JSR .NET CONTROL PANEL 20

 Pulsing..... 20

 Power Limit Status..... 20

PUREVIEW INSTRUMENT CARE 21

 EQUIPMENT REPAIR 21

 TECHNICAL SUPPORT..... 21

APPENDIX A - PUREVIEW SPECIFICATIONS..... 22

 PureView Power Source: 22

 Pulsar 22

 Receiver 22

Miscellaneous 23

Environmental..... 23

Hardware Limited Warranty

Imaginant Inc. warrants that PureView instrumentation will be free from defects in materials and workmanship for a period of one year from the date of purchase. Imaginant will, at its option, repair or replace any PureView products that prove to be defective during the warranty period without charge for parts and labor.

This warranty does not apply to any defect, failure, or damage caused by improper use, handling, care, or tampering such as damage to the finish or bent or broken connectors. Neither will this warranty apply to any equipment damaged from attempts by personnel other than Imaginant to repair or modify the product.

Imaginant disclaims any warranty, either expressed or implied, as to the merchantability or fitness of its hardware, software, or services for a particular purpose or application. Imaginant will not be liable for any indirect, incidental, or consequential damages, irrespective of whether Imaginant received any advance notice of the possibility of such damages.

To obtain service under this warranty, the customer must contact Imaginant to obtain a Return Material Authorization (RMA) number. Once the customer has obtained an RMA number, they must ship the defective product to Imaginant. The RMA number must be clearly marked on the outside of the shipping package. The customer is responsible for the costs associated with shipping, packaging, and insurance of the defective product. When Imaginant repairs or replaces a product, the warranty term is not extended.

Software Limited Warranty and License Agreement

Please refer to the JSR .Net Control Panel software documentation for warranty and licensing terms.

Application Disclaimer

This product is neither intended nor designed for use in medical, life support, or other devices or systems where malfunction of this product can reasonably be expected to result in personal injury. Any person or entity using this product in or selling it into such applications does so at their own risk and liability and thereby agrees to fully indemnify Imaginant Inc. against any damages resulting from such improper use or sale.

Powering PureView Instruments

It is highly recommended that all models of PureView Pulsar-Receivers be supplied with USB power from an independently-powered USB hub or from a PC's USB port that offers enhanced-power. A powered hub capable of supplying at least 1A and preferably 2A of current to the PureView instrument is sufficient. This level of current is required for supplying power to the PureView pulser, especially when power is first applied to the PureView instrument at the start of each usage session.

Product Package Contents

The following items are included in the PureView shipping box:

1. PureView Pulsar-Receiver
2. USB cable, Type A to Mini-B

Additional Equipment Required (Customer Supplied)

1. Computer running Windows O/S with an available USB port, preferably an enhanced-power USB port.
2. Ultrasonic Transducer(s).
3. Trigger-signal source (if external triggering of the PureView unit is required).
4. Oscilloscope or waveform digitizer.
5. 50 Ω coaxial cables with SMA Male connectors.
6. Externally-powered USB Hub (optional but recommended).

Overview

PureView Instruments comprise a family of Pulsar-Receivers that are USB controlled and powered. The various PureView models span a broad range of operating frequencies that enable a correspondingly broad range of ultrasound system applications. User control of these instruments is achieved through commands sent from a computer to the instrument via the USB interface. The JSR .Net Control Panel Software, a Windows-based software application, provides such control, and programming information supplied with the Software Developers Kit (SDK) and Programmer's Manual allows a user to develop custom software programs for controlling PureView instruments.

All PureView models are designed to be physically interchangeable which allows users to rapidly alter their system configuration by interchanging models. PureView is an excellent choice for ultrasonic system applications such as flaw detection, quality assurance, material characterization and transducer testing. The PureView instrument enclosure is water resistant although care should be taken to keep the instrument dry.

Connections are easily made to PureView hardware by attaching coaxial cables to PureView's four female SMA interface connectors, and PureView Pulsar-Receivers synchronize with other system hardware by producing or accepting trigger pulses on the PureView Trig / Sync connector.

PureView instruments receive power through the USB interface. PureView is thus ideal for use in PC-based ultrasonic testing and inspection systems, and its small size and relatively low power consumption enable systems to be implemented using portable computers. PureView can be combined with A/D Boards or other signal detection and processing instrumentation to give system integrators the flexibility to optimize system cost and performance.

Theory of Operation

Communication with a PureView Pulsar-Receiver provides a user with control over the receiver input signal selection (T/R or Through), the receiver gain, the low-pass and high pass filter values, the pulser repetition frequency (PRF), the transducer damping, and the enable/disable control of the pulser power supply.

PureView Instrument Functional Blocks

A PureView Pulsar-Receiver is composed of the functional blocks shown in the following System Block Diagram.

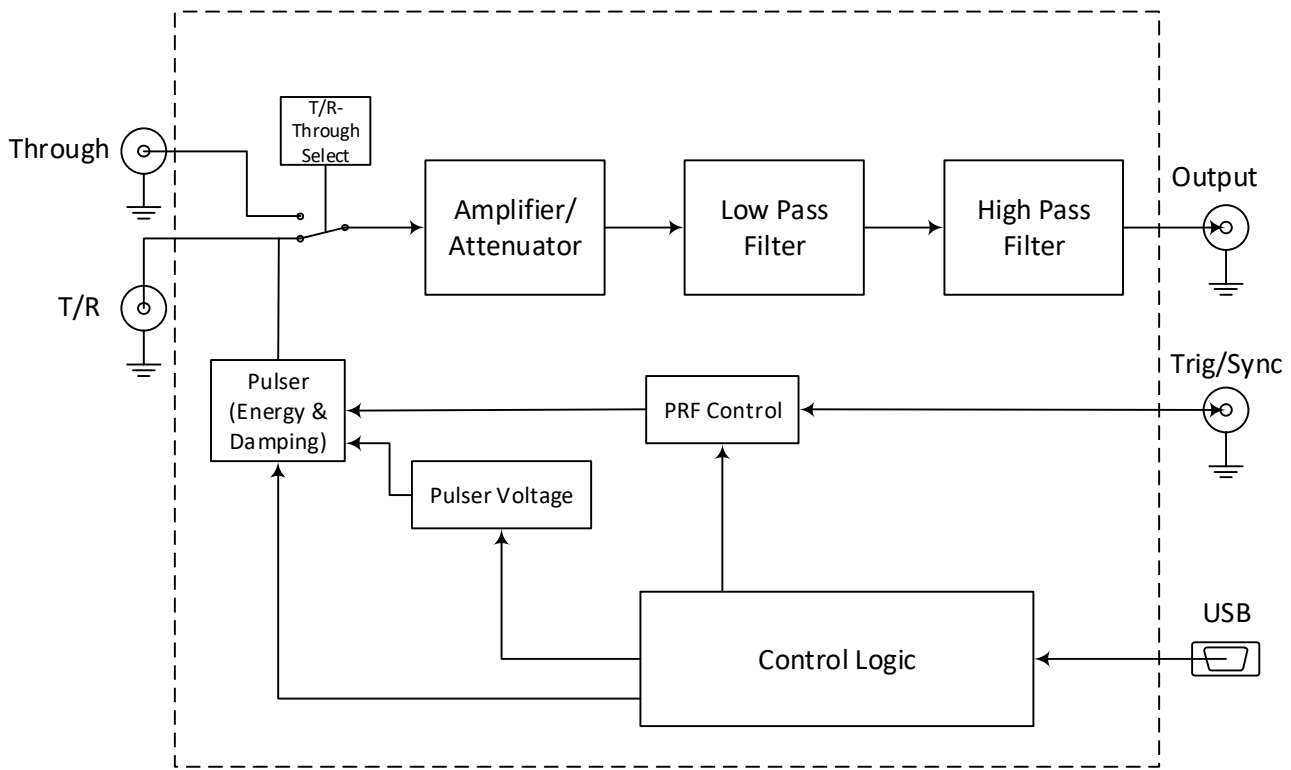

Figure 1: PureView System Block Diagram

Control Logic and USB Interface

The USB interface and associated control logic provides control of a PureView instrument through software resident on a host computer. A USB interface cable is supplied with the instrument.

Pulser (Energy and Damping)

The pulser generates a transducer-excitation pulse upon receipt of a trigger signal from a selected source, either internal or external. The Pulser energy and damping controls provide control of pulse parameters such as pulse duration, pulse energy and pulse amplitude. Note that a change to either the Energy or the Damping value will affect all three pulse parameters.

The pulser produces constant-amplitude pulses over the specified range of pulse repetition frequency. The JSR .Net Control Panel software and SDK software provide “power limit status” indications to warn a user when PureView might be functioning beyond the specified range of pulser operation, i.e. at too high a Pulse Repetition Frequency (PRF) which may result in reduced-amplitude of the transducer-excitation pulses.

Pulser Voltage

The pulser voltage supply provides power to the PureView pulser circuitry. The pulser voltage may be enabled or disabled which allows a user to assess signals that are present in a test system with and also without generating a transducer excitation pulse on the T/R connector. This can be useful for test system debugging.

T/R and Through Select

Selecting the “T/R” mode (also referred to as “Echo” mode) connects the T/R connector to the Receiver input. This configures the instrument for performing Transmit/Receive measurements with a single transducer.

Selecting the “Through” mode connects the Through connector to the Receiver input. This configures the instrument for performing Through measurements using a transmit transducer and a separate receiving transducer.

Amplifier/Attenuator

This functional block provides control over the PureView receiver’s gain. The receiver gain can be set in 0.5dB increments across the gain range of -11.5dB to +70db.

Low Pass Filters

The low-pass filter enables a user to reduce the bandwidth of the PureView receiver to improve the signal to noise ratio or to eliminate out-of-band signal content for applications that do not require the full receiver bandwidth. Two user-selectable low-pass filter values are available.

High Pass Filters

The high-pass filter enables a user to eliminate low frequency energy from the PureView receiver signal, and also to improve the rate at which the receiver output returns to its baseline level after the Pulsar excites the transducer. Two user-selectable high pass filter values are available.

PureView Enclosure, Interface Connectors, and Status Indicators

PureView Pulsar-Receivers have four coaxial SMA connectors, a mini USB connector, and LED status indicators.

PureView T/R and Through Connectors

As shown in the image below, all PureView models have two coaxial SMA connectors (labeled T/R and Through) for interfacing with one or two ultrasonic transducers.



In the Transmit-Receive T/R (Pulse-Echo) mode of operation, a single transducer is connected to the T/R coaxial connector, preferably via a very short length of coaxial cable. The PureView pulser generates a transducer-excitation pulse on the T/R connector to excite the transducer. The transducer converts energy from the electrical excitation pulse into an ultrasonic pulse that is propagated into a test material. Ultrasonic return signals (echoes) that are reflected from within the test material are received by the transducer and are presented to the receiver input via the T/R connector for amplification and filtering.

In the Through mode of operation, a transmitting transducer is connected to the T/R connector, and a second receiving transducer is connected to the Through connector. This second transducer detects signals that have propagated to it from the T/R transducer, usually after passing through a test material located between the two transducers. The signals received by the second transducer are presented to the receiver input via the Through connector for amplification and filtering.

PureView Receiver Output, Trig/Sync, and USB Connectors

PureView employs the three connectors shown in the following image for interfacing with other instrumentation. These three connectors are a Mini-B USB connector for instrument power and control, and two SMA coaxial connectors labeled Output and Trig / Sync.



PureView receives its power via the USB interface connector and is controlled through this same interface.

The PureView Receiver's output signal is available on the SMA coaxial connector labeled 'Output'. The Receiver circuitry amplifies signals from either the T/R or Through input connectors and presents the amplified signals on the Output connector. A high-quality 50 Ω coaxial cable should be employed to make a connection from the PureView Output connector to other instrumentation such as an oscilloscope or waveform digitizer. This 50 Ω coaxial cable must be terminated with a 50 Ω load to properly terminate the coaxial cable. The PureView Receiver can provide a linear output signal of +/- 500mV maximum into a 50 Ω load, and signals of interest should not be amplified beyond these limits. Over-amplification of signals will lead to signal distortion.

The Trig / Sync coaxial connector is used to synchronize the PureView unit with external hardware for External Triggering and Internal Triggering.

External Triggering: When the PureView pulser is set to External Trigger mode, an external trigger signal must be applied to the Trig / Sync SMA connector to cause the pulser to produce a transducer-excitation pulse on the T/R connector. The trigger signal must be nominally at 0V (ground) and consist of a positive-going pulse between 1V and 5V in amplitude. The pulser will then generate a negative-going transducer-excitation spike-pulse on the T/R connector in response to each positive transition of the trigger signal. Additional details of this mode of operation are contained in the Operation section.

Internal Triggering: When the PureView pulser is set to Internal Trigger mode, the pulser will generate a negative-going transducer-excitation spike-pulse on the T/R connector at a rate defined by the Pulse

Repetition Frequency (PRF) value that is set by control software such as JSR .Net Control Panel. To synchronize the PureView operation to other instruments such as an oscilloscope or waveform digitizer, a ~4V positive-polarity Sync pulse is generated on the Trig/Sync connector in synchronization with the transducer-excitation pulse. This Synchronization Pulse can then be used to trigger an oscilloscope or waveform digitizer to capture the waveform present on the PureView Output connector. Additional details of this mode of operation are contained in the Operation section.

PureView Status Indicators

The PureView front panel has Power and Pulse LED indicators that illuminate to indicate the instrument status as shown in the image below.

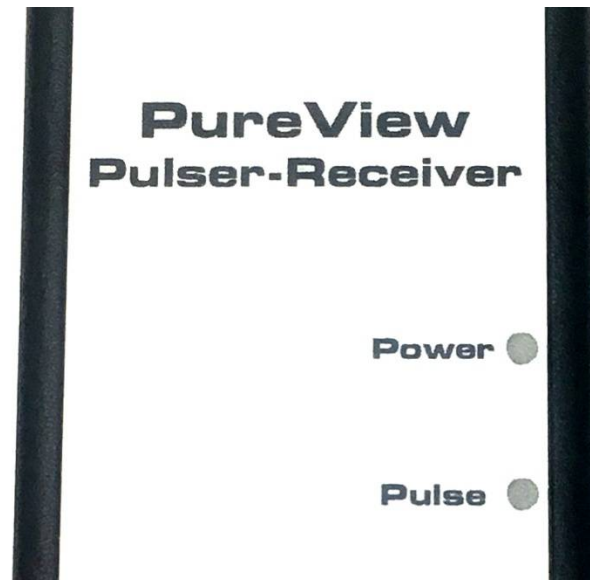

The Power and Pulse LED indicators indicate the following:

Indicator	Function
Power	The Blue LED indicates that the PureView Pulsar-Receiver is powered On. This LED can be set to blink (if desired) to identify a particular PureView instrument in a system incorporating multiple PureView instruments.
Pulse	This Red LED indicates that the unit's pulser is being triggered. When triggered, the pulser will produce transducer-excitation pulses on the T/R connector if the pulser voltage supply is enabled.

PC Setup

JSR .Net Control Panel software is a Windows application written and distributed by Imaginant Inc. You may install this software on a PC running the Windows® operating system version 7 with SP1, 8.0, 8.1 or 10. Once you download the software, locate the software installer package and double-click the Setup.exe icon.

Depending on your Windows O/S version, you may need Administrator privileges to run the Setup application. After you accept the license terms, the software will be installed automatically. The software can then be launched by clicking the JSR .Net Control Panel icon in the JSR Ultrasonics folder accessed via the Start menu.

With JSR .Net Control Panel installed, you can connect the PureView instrument to the PC directly using the supplied USB cable. However, it is highly recommended that the PureView instrument be connected to the PC through a powered hub that can supply at least 1A of current (preferably 2A) to power the PureView unit. The first time that a PureView instrument is connected to your PC, there may be a slight delay as the operating system finds and loads the hardware driver necessary for communication with the PureView unit.

To configure a system composed of a PureView instrument and a control PC:

1. Download JSR .Net Control Panel onto the PC.
2. On the PC, locate the software installer package and double-click the Setup.exe icon. The JSR .Net Control Panel software will be installed. Administrator account permissions may be required for the installation.
3. Run the JSR .NET Control Panel program to control the PureView instrument.
4. Plug the supplied PureView USB cable into the PureView Mini-B USB connector. Plug the other end of the USB cable into a USB port on your PC (although it is highly recommended that the PureView instrument be connected to the PC through a Powered Hub capable of supplying 1A to 2A of current). The blue power LED indicator on PureView should illuminate. The first time that a PureView unit is connected to the PC, there may be a slight delay as the operating system finds and loads the hardware driver required for control and communication.

System Configuration

Refer to the following two figures when configuring a PureView instrument into a test system.

Connect the PureView 'Output' connector to the input of an oscilloscope or waveform digitizer. The input impedance of the oscilloscope or digitizer should be 50 Ω . If the input has a high impedance such as 1M Ω , then a pass-through coaxial 50 Ω terminator should be added to the input.

Connect the PureView 'Trig / Sync' connector as follows:

Internal Triggering: If the PureView pulser is to be triggered by its internal PRF oscillator, connect PureView's 'Trig / Sync' connector to the trigger input of an oscilloscope or waveform digitizer. This allows the oscilloscope or waveform digitizer to be synchronized to the PureView pulser. The trigger input of the oscilloscope or digitizer may be terminated in 50 Ω .

External Triggering: If the PureView pulser is to be triggered from an external source such as a Sync signal generated by a waveform digitizer, connect PureView's 'Trig / Sync' connector to the trigger output of the waveform digitizer. The input impedance of the PureView Trig/Sync connector should be set via control software to 50 Ω so as to properly terminate the 50 Ω connecting cable.

Connect the PureView connectors labeled T/R and Through as follows (depending on whether Pulse-Echo or Through operational modes are desired):

Pulse-Echo Configuration

Pulse-Echo operation (also referred to as Transmit/Receive operation) employs a single transducer for both transmitting and receiving ultrasonic pulses. To configure PureView for T/R operation, the transducer is

connected to the PureView T/R connector. This connection should be made using a short length of high-quality coaxial cable. Pulse-Echo mode operation and configuration is shown in the following figure.

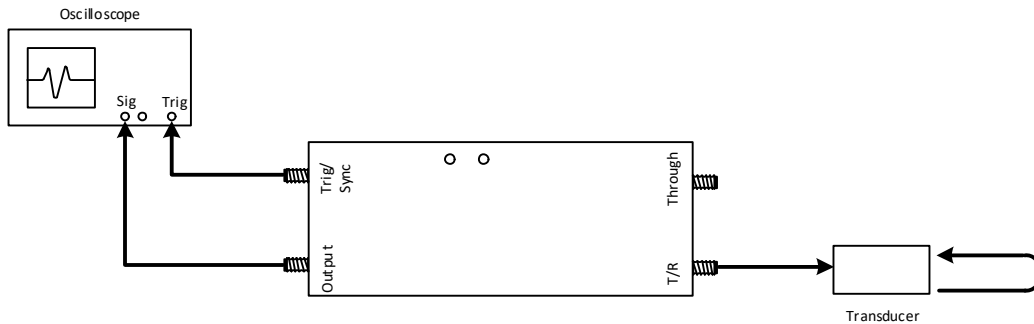

Figure 2 - Pulse Echo Mode Operation

Through Mode Configuration

Through operation employs a transmit transducer and a receive transducer. The transmitting transducer is connected to the PureView T/R connector and the receiving transducer is connected to the Through connector. Through mode operation and configuration is shown in the following figure.

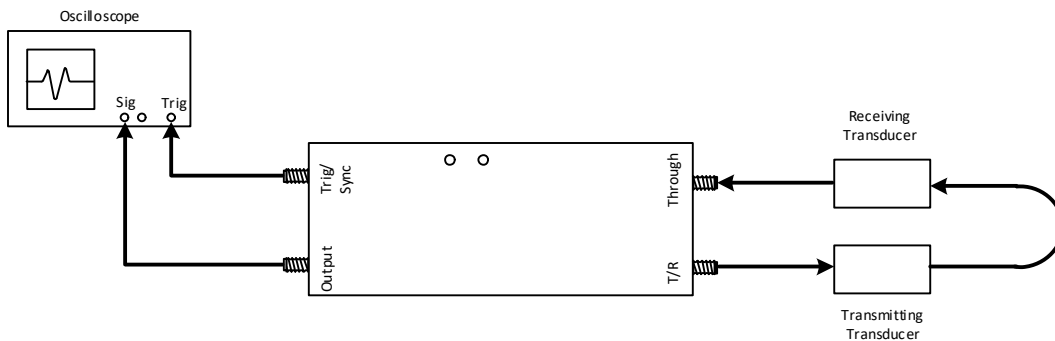

Figure 3 - Through Mode Operation

PureView Operation

The following sequence of actions describes a typical operating session with a PureView-based measurement instrument.

1. Configure the PC as described in the 'PC Setup' section and the PureView unit as described in the 'System Configuration' sections above.
2. Connect a transmit/receive transducer, or separate transmit and receive transducers to the PureView instrument. Given that high frequency ultrasound will not pass through air, a suitable acoustic coupling material must be present between the transducer(s) and the sample that is to be tested.
3. Use the control software to configure the PureView instrument for the desired operation, either Internal or External Trigger mode, and Pulse-Echo or Through mode.

The PureView red status indicator 'Pulse' LED will illuminate to indicate that the pulser is being triggered. Enable the pulser power supply to produce transducer excitation pulses on the T/R connector. Adjust the frequency of pulser firing such that all echoes from one excitation pulse have subsided before a new excitation pulse is generated.

Adjust the Damping and Energy controls to obtain the desired excitation pulse characteristics.

Adjust the receiver gain control so that signals of interest (signals from the PureView Output connector) do not exceed the range of +500mV to - 500mV into a 50Ω termination.

Adjust the high and low pass filter cutoff frequencies (as desired). The High pass filters can be used to eliminate low-frequency energy from signals of interest. The low pass filter can be used to reduce the receiver bandwidth and improve the signal to noise ratio.

IMPORTANT NOTE - The PureView receiver contains circuitry to protect its receiver from the large transducer excitation pulse. The operation of this protection circuit causes two short pulses to appear in the receiver Output signal, and these pulses bracket the time when the pulser 'fires'. The first short pulse occurs approximately 70ns after the rising edge of the Trig / Sync signal. The second short pulse follows the first by 300ns or more (depending on the PureView model).

The Receiver Output signal will not provide any ultrasound signals from its T/R or Through inputs during the interval of time between these two short pulses. During this interval the Receiver Output waveform contains no meaningful signal content. Although the two short pulses may look similar to ultrasound signals, neither of these short pulses is representative of any signals produced by the transducer(s) during that interval.

An example of the receiver-protection pulses is shown below. This is the output of a PureView unit where the horizontal time scale is 100ns / major division. The purple trace is the PureView Trig / Sync pulse. The blue trace is the Receiver Output signal with the Receiver gain set to 20dB. The two short pulses in the (blue) Receiver Output waveform follow the rising edge of the (purple) Trig / Sync pulse by 70ns and 640ns respectively. The exact timing of these pulses is PureView model dependent and the second pulse may appear earlier or later in time than what is shown, depending on the model. In some low frequency PureView models, the second pulse may occur up to 1.2us after the rising edge of the Trig / Sync signal.

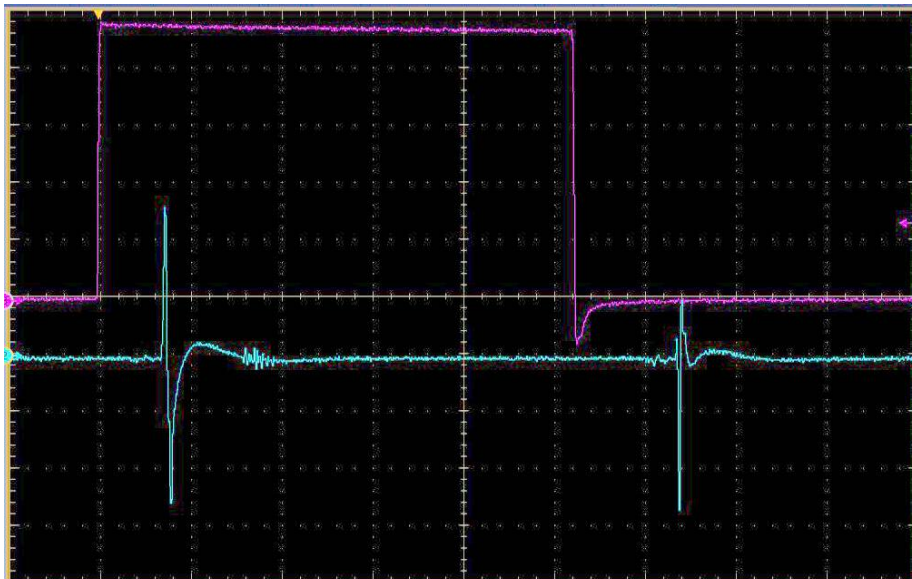

The transducer excitation pulse (typically) occurs 160ns after the rising edge of the Trig / Sync signal. As can be seen in the image above (with a horizontal timescale of 100ns/division), the pulser creates a small disturbance in the receiver output waveform (blue trace) 160ns after the Trig / Sync signal's rising edge (purple trace). This is what appears as a small noise burst 160ns (blue trace) after the rising edge of the (purple) Trig / Sync signal.

As described above, the receiver protection circuit does not allow ultrasound signals to pass through the receiver in the interval between the two short pulses. However, to more precisely determine the point in time when the receiver begins passing ultrasound signals, a good indication is when the random noise level in the output signal returns to the same amplitude as before the pulser fired. As an example, the image below shows the output signal of a PureView unit with the receiver gain set to 70dB. The horizontal time scale is 500ns / major division. The action of the receiver-protection circuit can be seen during the interval when the noise level in the receiver output signal is reduced. Shortly after the receiver protection ends, the random noise in the receiver output signal returns to its normal amplitude. At this point in time the receiver is once again able to pass signals from its input through to its output.

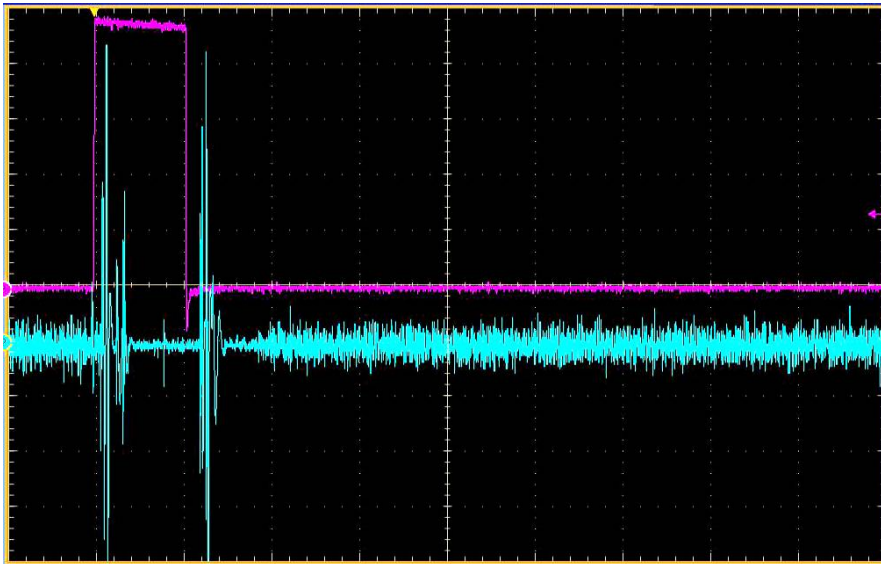

Using JSR .Net Control Panel Software

For installation of the JSR .Net Control software, refer to the 'PC Setup' section of this manual.

The JSR .Net Control Panel software enables a user to remotely control a PureView instrument from the user's computer running the Windows operating system. In addition to the JSR .Net Control Panel program, an SDK is available for users that wish to develop custom instrument control software.

Instrument control is provided through commands sent to the PureView instrument via the USB interface. The available control functions are given below.

Receiver Controls in JSR .Net Control Panel

Power LED

User selectable as a constantly-on power indicator or as a blinking indicator (to identify one PureView unit from among multiple units in a multi-unit system).

Receiver Mode

This control selects the source for the Receiver's input signal as either Pulse Echo (selects the T/R connector) or Through (selects the Through connector).

Gain

This allows a user to select the Receiver gain from -11.5dB to +70dB in steps of 0.5dB.

Low Pass Filter

This control selects either of the Receiver's two low-pass filter values. Depending on the PureView model, the low-pass filters may have values of 150MHz, 300MHz, 500MHz, or other values.

High Pass Filter

This control selects either of the Receiver's two high-pass filter values. Depending on the PureView model, the high-pass filters may have values of 1MHz, 5MHz, 30MHz, 65MHz, or other values.

Pulsar Controls in JSR .Net Control Panel

Trigger Enable

This control allows a user to enable or disable the Pulsar from responding to trigger signals.

Trigger Source

This control selects either Internal or External modes of pulsar triggering.

For Internal triggering, the pulsar is triggered at the rate set by the PRF control that is described below. A positive-going Sync pulse is produced on the Trig / Sync connector in synchronization with the pulsar firing.

For External triggering, the pulsar is triggered by the rising edge of a Trigger Input Signal applied to the Trig / Sync connector.

If the trigger rate exceeds the maximum pulse repetition frequency (PRF) for the PureView model, the amplitude of the transducer excitation pulse (on the T/R connector) may be reduced.

PRF

The Pulse Repetition Frequency (PRF) sets the rate of pulsar firing rate when a PureView unit is set for internal trigger mode. The range of PRF values available is dependent on the PureView model.

Pulsar Voltage Supply Enable

This checkbox in the software enables or disables the power supply voltage that is supplied to the Pulsar circuitry. Disabling (unchecking) this control will allow all Pulsar-Receiver functions to run but the Pulsar will not generate transducer excitation pulses. This control can be useful for debugging PureView-based test systems.

Pulsar Voltage

This displays the pulsar power supply voltage. For PureView, this is typically a fixed value that cannot be adjusted.

Pulsar Energy

This control selects the pulsar's energy level. This control will be disabled (greyed out) for PureView units that have a fixed pulse energy value.

Damping

This control allows the user to select between transducer-damping values. This control will be disabled (greyed out) for PureView units that have a fixed (single) damping value.

Trigger Zin

This control is used when a PureView unit is set to External Trigger mode and the external trigger signal is sent to the PureView unit using a 50 Ω coaxial cable. The 'Trigger Zin' control allows a user to set the input impedance of the Trig / Sync connector to either 50 Ω or High Z (~18k Ω). Selecting a value of 50 Ω connects an internal 50 Ω terminating impedance to the Trig / Sync connector which is appropriate for terminating a 50 Ω coaxial cable.

You may set the Trigger Zin control to 'High Z' to provide a high impedance (~18k Ω) to the Trig / Sync connector. This would be appropriate for trigger signals originating from a high-impedance source.

Multiple PureView instruments set to External Trigger mode can be triggered from the same external trigger signal. To do so, their Trig / Sync connectors should be daisy-chained together so that the trigger signal goes to a first PureView unit, then to a second, then to a third, etc. The 'Trigger Zin' value of each of these PureView units (except the last PureView unit) must be set to 'High Z'. For proper termination of the coaxial signal, the last PureView in the daisy chain should have its trigger input impedance set to 50 Ω .

Instrument Status Indicators in JSR .Net Control Panel

Pulsing

The pulsing status LED indicator in the JSR .Net Control Panel software will illuminate red when the pulsar is actively pulsing, and will be grey otherwise.

Power Limit Status

The Power Limit Status light will be green when the PureView pulsar voltage is nominal. At high pulsar firing rates (PRF rates) that may cause the pulsar voltage to droop, the Power Limit Status light will turn red.

PureView Instrument Care

The PureView encasement is water resistant but not waterproof. Be careful not to immerse the PureView instrument in liquids or to operate it in an environment where it is continuously sprayed by liquids. Should the instrument become wet, carefully dry it.

Cleaning the PureView instrument may be performed using a clean cloth dampened with isopropyl alcohol.

Do not drop the PureView instrument as this may damage its coaxial connectors and its internal circuitry.

Do not disassemble the PureView instrument. Opening the case will void the product warranty.

The PureView instrument is intended for use in a static-free environment.

Equipment Repair

If the PureView unit requires repair, contact your PureView Technical Support Representative. The Representative will be able to recommend whether the unit should be returned to the factory for repair. If a return is recommended, the Representative will ask for details regarding the repair issue and will issue an RMA number. If possible, when returning equipment to Imaginant, please package the equipment in its original shipping materials with the RMA number noted on the shipping documentation.

Technical Support

The answers to most questions regarding the use of the equipment are contained in this manual. If you cannot find an answer in this manual, please contact a member of Imaginant's Technical Service Team.

Toll Free: +1 888 577 8587
Telephone: +1 585 264 0480
Fax: +1 585 264 9642

Please have the following information available before contacting Technical Support.

- PureView serial number (from the serial number label on the bottom of the unit).
- JSR .Net Control Panel software version, found on the JSR .Net Control Panel menu item: Help → About JSR .Net Control Panel screen.
- Nature of the problem.

Pulsar/Receivers Sales and Support

Sales - E-mail: Sales@JSRUltrasonics.com

Technical Support - Email: TechSupport@Imaginant.com

PureView Instruments are manufactured by:

Imaginant Inc. <http://www.imaginant.com/>
3800 Monroe Avenue
Pittsford, NY 14534 USA

Appendix A - PureView Specifications

PureView Power Source:

It is highly recommended that all models of PureView Pulser-Receivers be supplied with USB power from an independently-powered USB hub or from a PC's USB port that offers enhanced-power. A powered hub capable of supplying at least 1A and preferably 2A of current to the PureView instrument is sufficient. This level of current is required for supplying power to the PureView pulser, especially as the PureView instrument powers up.

Pulser

Pulse Type	Negative Spike Pulse
Pulse Initial Transition	Model Dependent
Pulse Amplitude	Model Dependent
Pulse Energy	Model Dependent
Pulse Duration	Model Dependent
Damping Values	Model Dependent
Pulse Repetition Freq (PRF)	Model Dependent
Pulser Trigger Source	Internal or External, user selectable, rising-edge triggers Pulser
External Trigger Input Signal	1V to 5V positive-going pulse
Sync-Signal Output Pulse	Rising edge transition <3ns, Width < 600ns, +4V minimum into a 50 Ω load
Delay, Trigger Edge to Pulser Fire	160 ns typical

Receiver

Gain	-11.5 to 70 dB in 0.5 dB steps
Phase	0° (noninverting)
Bandwidth	Model Dependent
High Pass Filter	Model Dependent
Low Pass Filter	Model Dependent
Receiver Spot Noise	Typically < 1.3nV/Sq.Rt.Hz, input-referred
Input Modes	Pulse-Echo or Through Transmission, user selectable
Isolation between Inputs	60dB typical
Receiver Input Impedance	50 Ω
Receiver Output Impedance	50 Ω (Receiver output should be terminated in 50 Ω)
Linear Output Signal Range	+500 mV to -500 mV with 50 Ω Termination. Signals beyond this range many exhibit some compression of signal peaks.
Receiver Protection (Blanking)	Start: 70ns (typical) following Rising Edge of Trig / Sync signal. Duration: PureView model dependent, ranging from 300ns minimum to 1.2us maximum.

Miscellaneous

Power

+5V DC power for PureView™ instrument operation is obtained from a powered USB port. A high-quality low-loss USB cable should be employed to avoid any voltage drop through the cable.

Physical

Weight	0.152kg (0.33 lbs.)
Enclosure Dimensions	124.5mm x 50.3mm x 25.4mm (4.9" L x 1.98" W x 1" H)
Length including SMA connectors	142.2mm (5.6")

Environmental

Operating Temperature	0 to 40 °C
Storage Temperature	-10 to 50 °C
Operating Humidity	<80% RH, non-condensing
Operating Altitude	<2000m